

INSTALLATION INSTRUCTIONS FOR DROPSPOT™ REMOTE CHILLER

RC-8000 Remote Chiller for Bottle Fillers



SLOAN® LIMITED WARRANTY SUMMARY

Sloan Valve Company ("Sloan"), warrants its products against defects in materials and workmanship, excluding damage caused by matters beyond Sloan's reasonable control. Instructions for filing claims can be found in the Limited Warranty which can be obtained at www.sloan.com or by requesting a free copy by telephone at 888.756.2614. Sloan will repair or replace your defective product, or provide a refund, as your exclusive remedy. This is only a general summary of Sloan's Limited Warranty so it is important to note that the specific terms, conditions, limitations and exclusions, including the duration of warranty coverage for your particular Sloan product, are contained in the actual Sloan Limited Warranty. The Limited Warranty is subject to applicable laws in your country, state, province or other jurisdiction—and disputes arising under the Limited Warranty are to be resolved by binding arbitration unless you provide Sloan with an opt-out notice no later than 30 days after your purchase date. In case of a conflict with this summary, the terms and conditions set forth in the complete Limited Warranty will prevail.

IMPORTANT INFORMATION

To ensure proper installation, review this document thoroughly and verify rough-ins before beginning any work. File this document with the owner or maintenance personnel upon completion of installation.

Sloan products are designed in accord with applicable National Codes and Standards, which may include UPC, ANSI, and ASSE. Installers should use industry standard practice for details not covered within this document. ANSI, UFAS or ADA compliance is subject to the interpretation and requirements of the local code authority and is the responsibility of the installer for verification.

Industry standard wall backing substrate, for wall hung fixtures, is required. Installer provided wall anchors and wall anchoring hardware must be appropriate for wall construction and be able to support three (3) times the weight of the unit (177 lbs.).

Electrical receptacle(s) must be wired to a GFCI protected circuit. Fixture must be earth grounded per NEC (National Electrical Code). It is common for electrical equipment to be grounded to water lines either within a structure or away from it. Every attempt should be made to prevent this kind of grounding creating electrolysis. Electrolysis will cause a metallic taste or cause water metal content to increase.

NOTICE: A dielectric coupling must be used to connect the water cooler to the water supply. A nonmetallic coupler is furnished with this water cooler to meet this requirement.

This fixture is intended for **indoor use only** and is not recommended for installation in environments where freezing temperatures or saltwater may be present.

WARNING: Warranty is voided if installation is not made following current Sloan installation instructions and if components are assembled to the fixture that are not approved by Sloan.

IMPORTANT INFORMATION, CONTINUED

1. Read installation instructions carefully and completely before proceeding.
2. Use caution when handling as sharp edges may be present.
3. Provide mounting surface, adequate to support three (3) times the weight of the fixture (177 lbs.).
4. Electrical Receptacle(s) must be wired to a GFCI protected circuit. Fixture must be earth grounded per NEC (National Electrical Code).
5. Water supply service stop valve, water connections, and electrical connections (not provided) must be in accordance with local codes.
6. Completely flush supply lines of all foreign debris before connecting to chiller. Water chiller is designed to be free of problems with taste, odor, or sediment.
7. All burrs must be removed from outside of cut tubes before inserting into components.
8. Power supply must be identical in voltage, cycle, and phase to that specified on the chiller data plate.
9. Fixture operates within water pressure range of 20 psi (138 kPa) to 105 psi (724 kPa). Sloan will not warranty product damaged when connected to supply lines with flow pressure lower than 20 psi (138 kPa) or higher than 105 psi (724 kPa). A pressure regulator must be furnished (not provided) on supply line if inlet pressure is greater than 105 psi (724 kPa). **Consult with UPC and local codes for maximum allowable water pressures; many building codes list maximum static water pressure at 80 psi (551 kPa).**

TOOLS REQUIRED FOR INSTALLATION

- Flathead or 1/4" nut driver (not included)
- Sloan Universal Maintenance Tool (included)

Universal Maintenance Tool
DO NOT DISCARD!



ROUGH-IN

Prior to roughing in, consult local, state, and federal codes for proper mounting height.

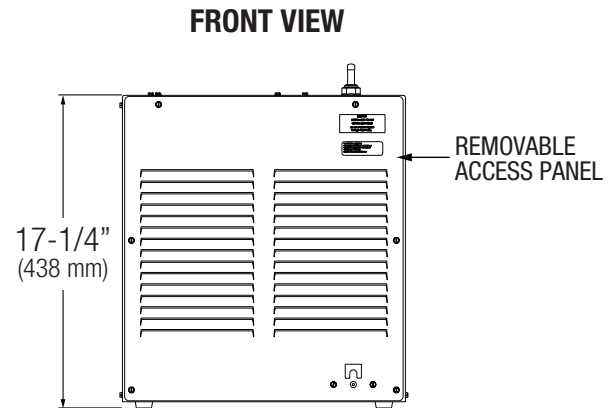
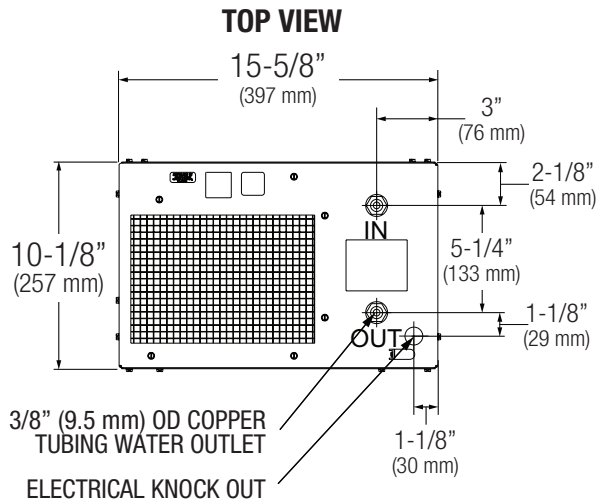

NOTE
 REMOVE ACCESS PANEL TO LOCATE JUNCTION BOX TO MAKE WIRING CONNECTIONS.

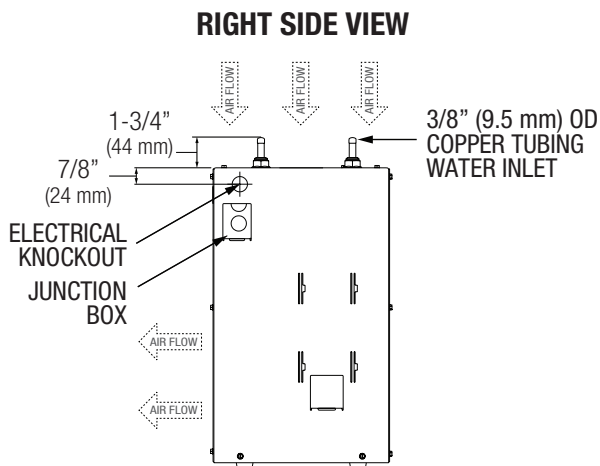

WIRING DIAGRAM
 115VAC / 60Hz / 4.6 AMPS / 8 GPH

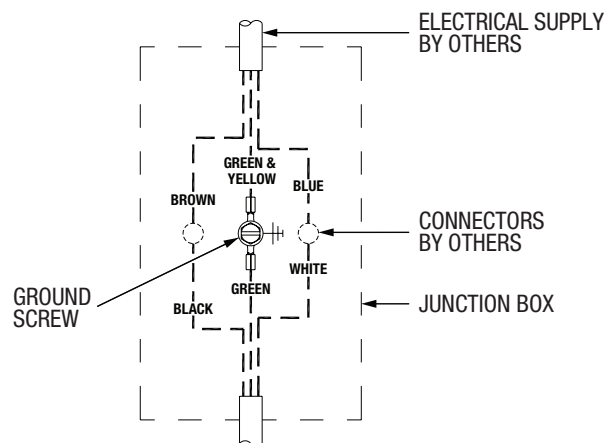

NOTES:

1. All dimensions are shown in inches (mm).
2. Allow 4 inches (102 mm) minimum clearance on top and front for proper ventilation.
3. All water outlets should be connected directly and be no longer than 6 feet away from the chiller. For anything greater than 6 feet, chilled water may not be exposed until all water in riser has been released. All chilled water piping should be covered with appropriate insulation to maintain temperature and prevent condensation.
4. Dry weight of unit: 59 lbs.

1 – INSTALLATION

- A** Locate chiller where there is 4 inches of space in front of and above the chiller for proper ventilation.
- B** **IMPORTANT: Ensure the supply power is off.**
- C** Remove front panel and make the necessary electrical connections including the ground connection.
See WIRING DIAGRAM on the previous page.
- D** With the front panel still removed, carefully rotate the cooling fan manually to ensure proper clearance and free fan action.
- E** Reinstall the front panel with six (6) sheet metal screws.
- F** Connect the water supply stop (not provided) to the inlet on top of the chiller. If you have a filter, make sure to route the filter before the chiller.
IMPORTANT: Ensure the water supply lines are thoroughly flushed of any debris before connecting to the chiller.
- G** Connect the outlet on top of the chiller to the fixture(s) requiring chilled water. All tubing supplying chilled water must be covered with appropriate insulation to maintain temperature and avoid condensation.
IMPORTANT: Tubing connections to fixtures should be direct and no longer than six (6) feet.

2 – STARTUP

- A** Before connecting the power supply, but after thoroughly flushing the supply line and connecting it to the chiller, turn on the building water supply and check all connections for leaks.
- B** Air within the water chiller system or the structure supply piping will cause an irregular outlet stream until purged out by incoming water. Cover the outlet of the fixture to which the chiller is connected with a cup to prevent excessive splashing.
Activate bottle filler until steady water stream is achieved.
- C** Recheck all water connections with water flowing through the system for leaks.
- D** Connect power supply to chiller.

TROUBLESHOOTING GUIDE

IMPORTANT: BEFORE MAKING ANY OF THE REPAIRS LISTED, ENSURE PROPER ACCESS TO THE ELECTRICAL SUPPLY AND THE WATER SUPPLY VALVE IN THE EVENT THEY ARE NEEDED.

DO NOT ATTEMPT TO TROUBLESHOOT OR SERVICE THE COOLER IF YOU ARE NOT A QUALIFIED ELECTRICAL OR REFRIGERATION TECHNICIAN.

1. COMPRESSOR DOES NOT RUN:

- A.** Check the electrical supply for power and correct voltage. The incoming voltage must be within 10% of the rated voltage on the serial nameplate.
- B.** Check if the cold thermostat capillary bulb is kinked, it will fail in the open position causing a disruption of power to the compressor. Remove the chiller front panel. The cold thermostat is located at the bottom right. Disconnect electrical supply to the chiller and using an ohm meter, check for continuity across the two electrical terminals on the thermostat.
- C.** Check for loose wires within the compressor box. The incoming power leads must be connected to the overload relay (see diagram at right).
- D.** If all components check positive for continuity, then test the wiring harness plug for continuity to see if there is a broken wire within the wiring harness insulation.

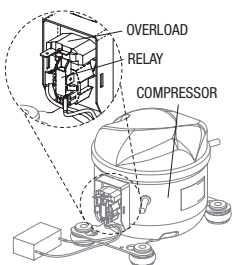

2. COMPRESSOR RUNS, WATER IS WARM:

- A.** Disconnect power. Make sure the condenser fan motor is operative. The fan blade must turn freely to help remove the heat of compression.
- B.** Loss of refrigerant, an incorrect refrigerant charge, restriction, or an issue with the compressor (not pumping) will also cause the compressor to run without producing cold water. Replace chiller.
- C.** Ensure the water line from the remote chiller to the bottle filler is no longer than 6 feet.

3. COMPRESSOR CYCLING ON OVERLOAD PROTECTOR:

- A.** Disconnect power. Check for a dirty condenser or a blocked fan, which causes a high head pressure and frequent cycling of the overload protector. Clean condenser and/or ensure the fan can rotate freely.
- B.** Check the incoming voltage to make sure it is within 10% of the serial nameplate rating located on the chiller.
- C.** Check for a restriction or moisture in the system. Replace chiller if necessary.

4. NOISY OPERATION:

- A.** Disconnect power. Check to make sure the fan can rotate freely.
- B.** Check the compressor mounting to make sure the pins and clips are not rattling. If the compressor appears to be making noise internally, then it should be replaced.

5. RESTRICTED OR NO WATER FLOW:

- A.** Ensure water supply service stop valve is fully open.
- B.** Verify minimum 20 psi (138 kPa) supply line flow pressure.
- C.** Check for twists or kinks in outlet tubing.
- D.** Check shut-off valve, water activated located inside the chiller. If it's tripped, the lever will be horizontal and the puck will be swollen. If tripped, replace puck.
- E.** Ensure the fixture to which the chiller is attached is clear of foreign material.
- F.** Check if the water chiller has developed a freezing condition in which the water will become frozen inside the evaporator coil. Unplug the unit and wait twelve hours to allow frozen water to melt, then plug the unit back in. If the problem persists, contact Sloan Tech Support.

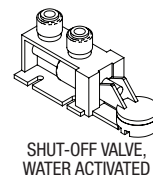

When assistance is required, please contact Sloan Technical Support at 1.888.SLOAN.14 or 1.888.756.2614.

CLEANING AND PREVENTATIVE MAINTENANCE

Motors include lubrication for lifetime of product and do not require replenishment. Excess dirt or poor ventilation will cause the compressor overload protector to turn the compressor off and it will cycle on and off with no cold water coming out of the bottle filler. Periodically clean condenser fins and cabinet ventilation louvers with vacuum cleaner, air hose or brush. In environments where dirt and dust is more prevalent, clean more frequently.

PUSH-IN FITTINGS

NOTE: FITTINGS AND TUBE SHOULD BE KEPT CLEAN, BAGGED, AND UNDAMAGED PRIOR TO INSTALLATION.

TO CUT TUBE

If needed, use common PE tubing cutters, scissors, or a razor blade to cut to fit length of 1/4" tubing and remove any burrs or sharp edges. Ensure that the outside diameter is free from score marks. Tube ends should be square.



INSERTING THE TUBE

- 1 Firmly and fully insert the tubing end into the push-in fitting up to the tube stop located approximately 1/2" deep.
- 2 Pull on the fitted tubing to ensure it is secure. Tube should not come free from the fitting. Water test the connection assembly to ensure there are no leaks.

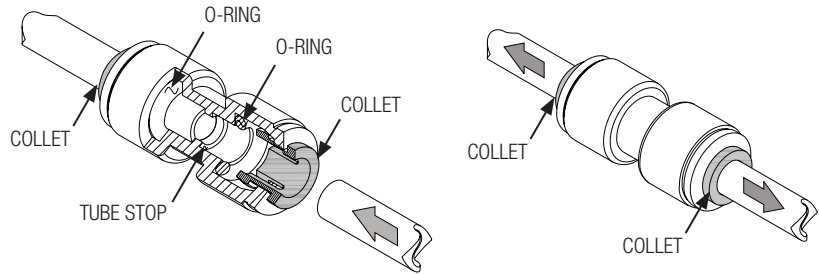

DISCONNECTING THE TUBE

To disconnect the tube from the fitting, ensure that the water line is depressurized. Use the Sloan Universal Maintenance Tool to push collet square/evenly towards the push-in fitting body and hold. While holding the collet in, pull on the tubing to remove from the push-in fitting.

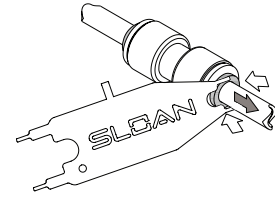

CHILLER PARTS BREAKDOWN

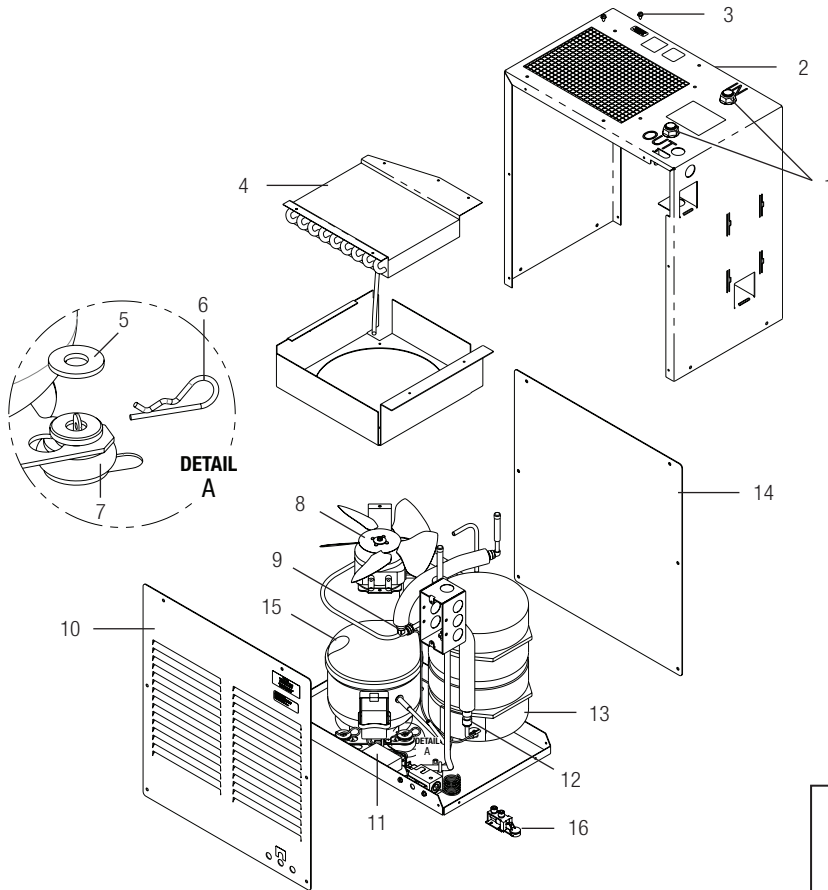

Item No.	Description
1	Bulkhead Connection
2	Housing
3	#8-3/8" Hex Washer HD Slotted Screw
4	Condensor Assembly
5	1" OD x 7/16" ID Flat Washer
6	3/32" x 1-5/8" Hitch Pin
7	Rubber Foot for Tatung
8	115V Fan Motor
9	1/4" OD Push-In Elbow Connection
10	Front Panel
11	Capacitor
12	1/4" OD Push-In Connection
13	Evaporator Assembly
14	Back Panel
15	115V Compressor Assembly
16	Shut-off Valve, Water Activated

When assistance is required, please contact Sloan Technical Support at 1.888.SLOAN.14 or 1.888.756.2614.

The information contained in this document is subject to change without notice.

SLOAN • 10500 SEYMOUR AVENUE • FRANKLIN PARK, IL 60131

Phone: +1.800.9.VALVE.9 or +1.800.982.5839 • Fax: +1.800.447.8329 • www.sloan.com